

1. PRECAUTION

Please read through this Manual before use the instrument for correct handling. Please keep this Manual carefully after use. This instrument has been thoroughly tested at the factory before shipment. When you receive it, visually inspect it for damage and check the accessories.

① Model number and specification check
Check to see model number and specifications on the nameplate attached to the front face of the instrument are as ordered.

② Contents of instruction manual
This instruction manual provides instructions on handling, external wiring and safety use of the distributor.

2. GENERAL

This instrument used together with 2-wire transmitter to feed power to it extracts 4~20mA DC signal and converts it into isolated current or voltage signal.

Accessories: Mounting block 2
Tag number label 1
Mounting screw M4 4

3. MOUNTING METHOD

JUXTA signal conditioners can be mounted on rack, wall or DIN rail.

3.1 Rack mounting

Use panel (FRK-16) and install it on an angle as shown in Fig.1. This is a convenient method for high density mounting on 19-inch rack panel. (See Fig.6)

3.2 Wall mounting

Use panel (FRK-16) to mount the distributor as shown in Fig.2 or directly mount the single unit on the wall. (See Figs.4 and 7 for mounting dimensions.)

3.3 DIN rail mounting

Insert DIN rail into the upper section of the distributor and fix the rail with the slidlock at the base of distributor as shown in Fig.3.

3.4 Angle mounting

If single unit is mounted without using the panel (FRK-16), refer Fig.5 for its mounting.

3.5 Mounting block installation and removal

Insert mounting block into distributor groove as shown in Fig.4 and slide it until it is fixed with the stopper. To remove it, lift up the mounting block stopper with (-) screwdriver and slide it along the groove.

4. EXTERNAL WIRING

CAUTION Wiring should be done after ensuring power break of each cable.

Wires should be connected to M4 screw terminals after opening distributor terminal cover as shown in Fig.10. For wiring, flexible twisted wires and good contact of durable round crimp-on terminals are recommended to be used.

● Signal wiring cable should has more than 0.5mm² and power cable should has more than 1.25mm² of nominal cross-sectional area of conductor.

Fig.1 Rack Mounting

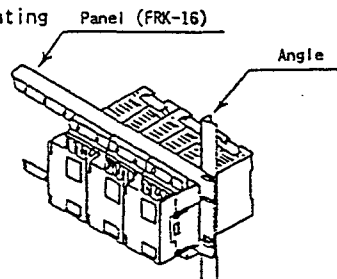

Fig.2 Wall Mounting

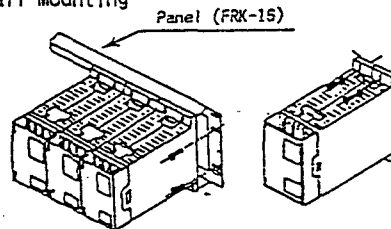

Fig.3 DIN Rail Mounting

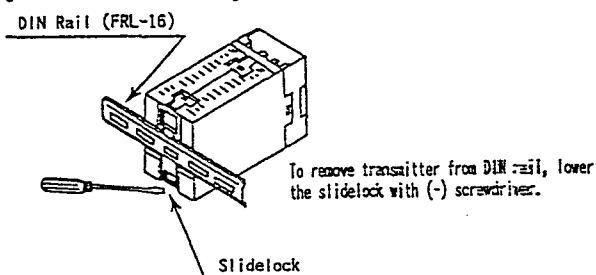

Fig.4 Mounting Block installation and removal

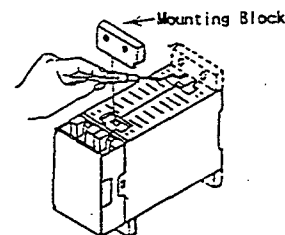

Fig.5 Angle Mounting Dimension

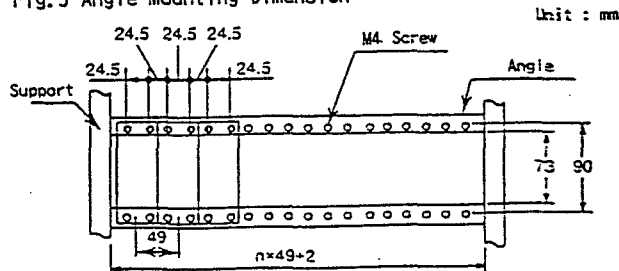
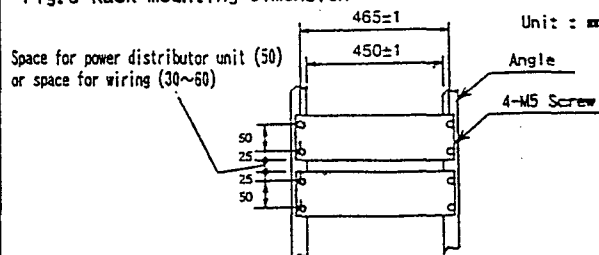

Fig.6 Rack Mounting Dimension



4.1 Wiring

- ① See Fig.8 for terminal arrangement.
- ② Connect 4~20mA DC signal cable from transmitter to distributor terminals 4(+), 7(-). Also, connect it to 7(+), 8(-) when use of external power supply (See Fig.9)
- ③ Connect distributor output signal cable to its terminals 11(+) and 12(-).
- ④ When use of dual outputs, connect Output-2 signal cable to 9(+), 10(-).
- ⑤ Connect 85~265V AC or 24V DC power cable to distributor terminals 14(L+), 15(N-) and 16(G). (See Fig.9)

NOTE : Apart wiring of power and input/output cables from noise source. Otherwise, accuracy may not be warranted.

5. INSTALLATION AND HANDLING

- ① Avoid installation in such environments as shock, vibration, corrosive gas, dust, water, oil, solvent, direct sunlight, radiation, powerful electric and magnetic fields.
- ② In order to protect distributor from inducement of thunder surges in power and signal cables, use arrester between distributor and equipment installed in the field.

6. SAFETY USE

Following caution for safety should be taken for handling of instrument. We are not responsible for damage incurred by use contrary to caution.

CAUTION

- Following items should be checked when turning power on. Use of instrument by ignoring the specifications may cause overheat or burning.
 - (a) Voltage of power supply and input value be applied to the instrument should meet with required specifications.
 - (b) External wiring to terminals should be connected correctly. (See preceding Article 4)
- Do not use the instrument in such dangerous places where exist inflammable and explosive gas or steam.
- In case of AC power supply, high voltage of 85~264V AC would be applied to 14 and 15 terminals during power on as shown in Fig.10. Do not touch terminals.

7. CALIBRATION

Carry out the following calibration after warming up the instruments for more than 10~15 minutes.

7.1 Calibration equipment

- Voltage/Current Generator (Yokogawa Model 7651 or equivalent) 1
- Voltmeter (Yokogawa Model 7551 or equivalent) 1
- Precision Resistor 250Ω±0.01% 1W 1 (Use for current output)

7.2 Calibration

- ① Connect each equipment as shown in Fig.10.
- ② Input/output characteristics check
Apply input signal equivalent 0, 6.25, 25, 56.25, 100% of span to distributor through Voltage/Current Generator.
Check the corresponding distributor outputs are 0, 25, 50, 75 and 100% respectively and are within accuracy rating range.
(Connect R in case of current output)
- If output signal is out of tolerance, adjust it through Handy Terminal (JHT-100 or JHT200). For adjustment, refer Instruction Manual of Handy Terminal.
(JHT200: IM JF81-02E, JHT-100: IM JF81-01E)

Fig.7 Panel (Wall) Mounting Dimension

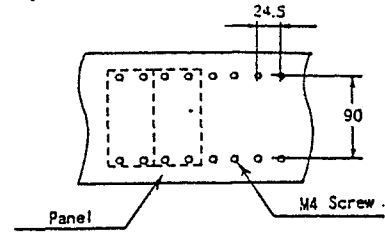
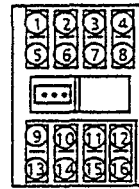

Fig.8 Terminal Arrangement



4	INPUT (PS+)
7	INPUT (-)
8	COM
9	OUTPUT-2 (+)
10	OUTPUT-2 (-)
11	OUTPUT-1 (+)
12	OUTPUT-1 (-)
13	
14	SUPPLY (L+)
15	SUPPLY (N-)
16	GND (G)

Fig.9 Wiring Diagram

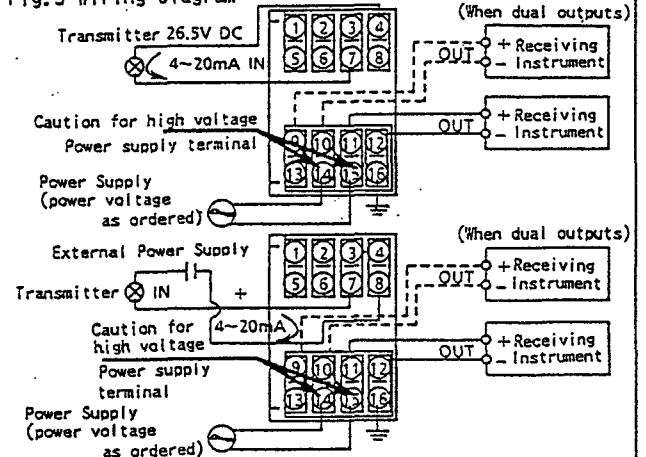

Fig.10 Wiring of Calibration Equipment

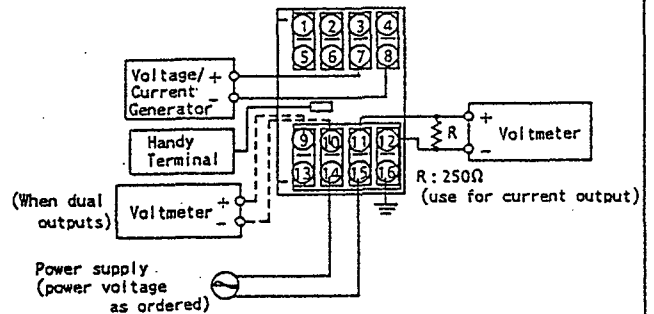
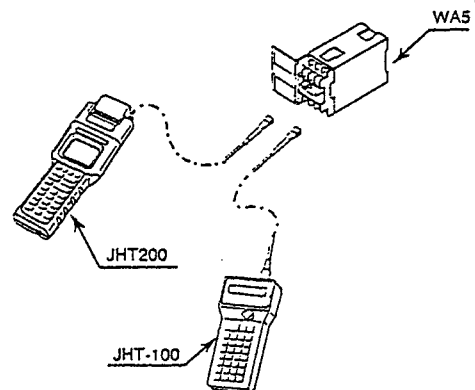

Fig.11 Connection to Handy Terminal



Subject to change without notice for grade up quality and performance.